



your reliable partner

Wind power plants

Safety brakes
Torque limiters
Shaft couplings



Picture credits

Title: fotolia/tobago77; Page 3 top: fotolia/Alexander Rochau, Drawing: Michael Paetow; Page 12: Skyman; Page 14 top: shutterstock/Coqrouge; Page 15 top: shutterstock/iweta0077; Page 16 top: fotolia/tobago77; Page 17 top: shutterstock/macknimal; Rest: *mayr*[®] power transmission



We make the generation of clean energy safe and efficient

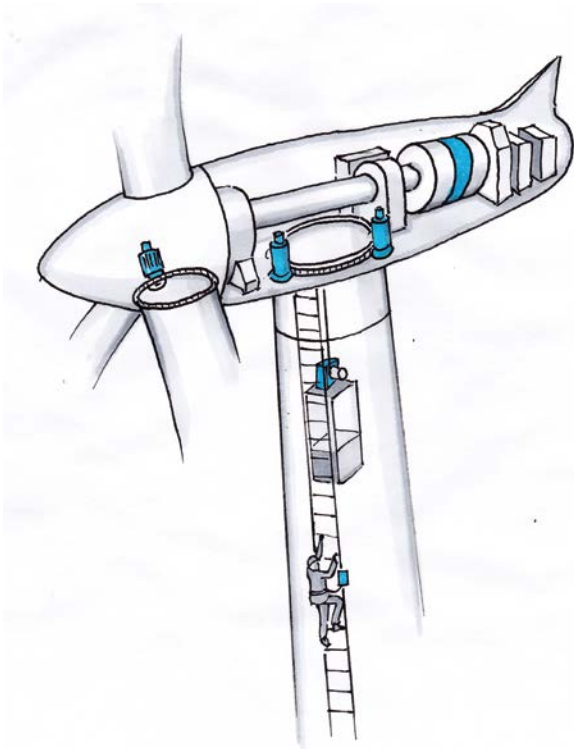

For more than 100 years, the company *mayr*[®] power transmission has stood for innovations and premium quality. *mayr*[®] power transmission bundles its know-how and decades of experience in the offshore sector in safety brakes for pitch and azimuth drives. The safety brakes for wind power plants represent maximum fail-safe function, minimum downtimes and constructional design diversity, and reduce the operating costs. The company sets new standards with its Cold Climate Version, which is certified for applications to -40 °C by Germanischer Lloyd (GL).

And the portfolio is also wide for torque limiters. It extends from overload systems for wind turbine gearboxes via torque limiters for climbing aid drives in the towers and switchable clutches for the drives of maintenance and installation platforms, right up to high-performance large clutches for gearbox test stands.

The products of *mayr*[®] power transmission - shown in blue in the adjacent diagram - are used in a wide variety of applications in wind turbines (see also overview on page 19).

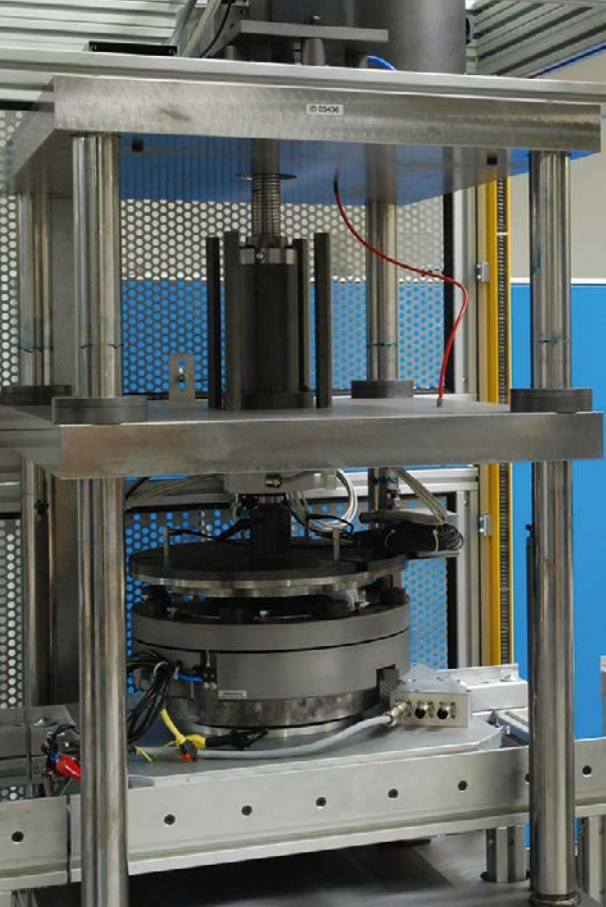

Expert know-how in development and design

As the technological leader, *mayr*[®] power transmission focuses on continuous further development. Today, highly qualified engineers and technicians work on tomorrow's innovations using the most up-to-date tools. The many years of experience and countless trials carried out by the Research and Development department at the headquarters in Mauerstetten form the basis for a conscientiously-planned service lifetime, taking into account realistic and verified braking torque tolerances.

The values upheld by our traditional, family-run company also include long-term stability and independence as well as a good reputation and satisfied customers.

Therefore, we place emphasis on:

- Tested product quality,
- Optimum customer service,
- Comprehensive know-how,
- Global presence,
- Successful innovations and
- Effective cost management.



Tested quality and reliability

mayr[®] brakes are subject to meticulous quality inspections. These include quality assurance measures during the design process as well as a comprehensive final inspection. Only the best, tested quality leaves our factory. All products are rigorously tested on calibrated test stands, and adjusted precisely to the requested values. An electronic database in which the measurement values are archived together with the associated serial numbers guarantees 100 % traceability. On request, we confirm the product characteristics with a test protocol.

The certification of our quality management according to DIN EN ISO 9001:2015 confirms the quality-consciousness of our colleagues at every level of the company.



Please take the following into consideration when selecting the wind power brakes

We have summarized further information on the topic of safe brakes in our flyer. The flyer FI.804.V_... is also available in the Internet on www.mayr.com/en/industry-sectors/wind-energy

Signed and sealed

So that you do not have to depend on promises, we have had branch-specific brakes, couplings and clutches tested and certified for safety-critical and unusual applications by independent institutes. They confirm our claims as to quality and reliability.

The Cold Climate Version of our ROBA-stop®-M safety brake sets new standards for pitch and yaw brakes in low-

temperature applications. It is the only electromagnetic safety brake certified by Germanischer Lloyd (GL) for applications to -40 °C.

These certified pitch and yaw safety brakes work reliably even in the most arduous climatic conditions and ensure the operation of your systems – even at temperatures of minus 40 °C.



ROBA-stop® brakes are certified according to the North American standards of the CSA and UL.



ROBA-stop®-M CCV
Pitch and azimuth brakes,
certified to -40 °C.

Strongly positioned

mayr® sets standards in power transmission with economically viable solutions. For maximum competitiveness of your machines and systems, we always aim for the best possible cost efficiency, starting with the development of your clutch/coupling or brake, right up to delivery of the finished and inspected product. For cost-efficient production, our factories in Poland and China represent the perfect supplement to the headquarters in Germany.



mayr® headquarters in Mauerstetten



Subsidiary with Production — mayr® China



Subsidiary with Production — mayr® Poland

World market leader for electromagnetic pitch brakes

ROBA-stop®-M safety brakes

mayr® power transmission as an internationally leading manufacturer offers safety brakes especially developed and tested for pitch drives with the ROBA-stop®-M brakes. In the pitch drives, the brakes have the important task of securing the rotor blades against twisting after angular positioning through the gear motors.

The new standard for Cold Climate applications

Here, well-founded know-how on the braking torque tolerances of the brakes used is extremely important. On the one hand, a sufficient braking torque must always be provided to hold the rotors; on the other hand, the maximum motor torque may not be exceeded on some system types in order to rotate against the closed brakes whilst still in vane position. This must work just as reliably for all ambient

conditions occurring in normal operation as for example at a relative air humidity > 90 % or at temperatures well under freezing point.

In order to guarantee reliable operational safety even in difficult climatic conditions, *mayr*® power transmission has therefore subjected the Cold Climate version of the brake – like all their products – to comprehensive tests. All function-relevant properties have been statically and dynamically inspected at ambient temperatures of -40 °C in collaboration with Germanischer Lloyd as the officially approved test institute. Today, the ROBA-stop®-M CCV is the only electromagnetic safety brake to have been certified by Germanischer Lloyd for applications to -40 °C.

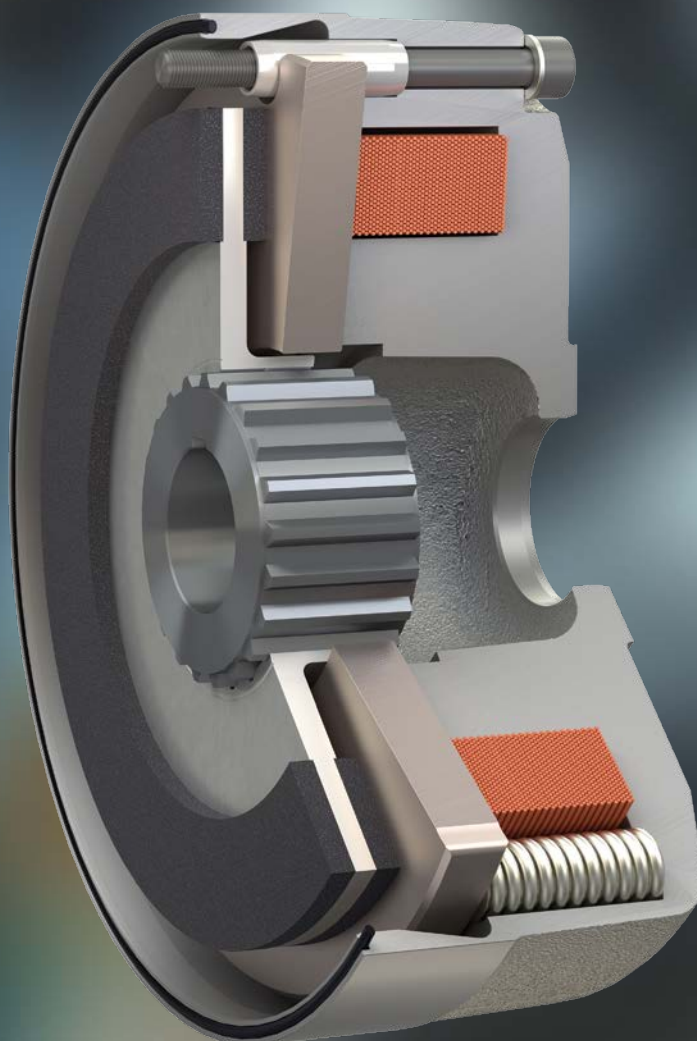

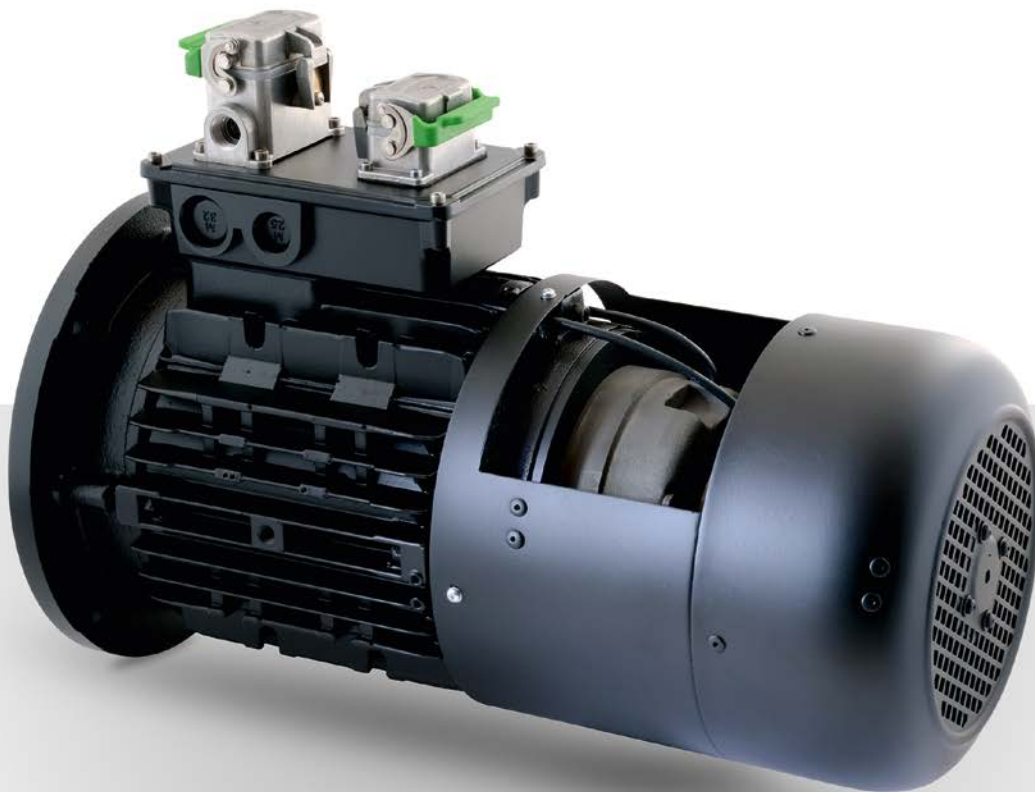

Your special requirements represent our standard

We offer a wide range of supplements and options for our ROBA-stop®-M safety brakes. These facilitate the adaptation of the brakes to the requirements of your applications. The most frequently-requested "special equipment" includes:

- Mounting preparation for encoders
- Damped rotor
- Extended corrosion protection
- UL-approved
- Microswitch for condition monitoring
- Hand release
- Continuous shaft
- Anti-condensation heating (recommended at temperatures below 0 °C)
- IP66

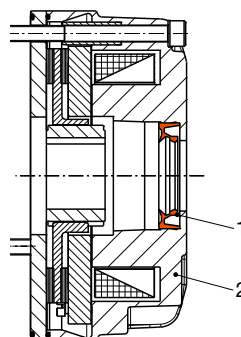

Continuous shaft:
The enclosed design (IP65) is equipped with a sealing plug or cover as standard. A radial shaft sealing ring (1) is installed in the coil carrier (2) on continuous shafts.

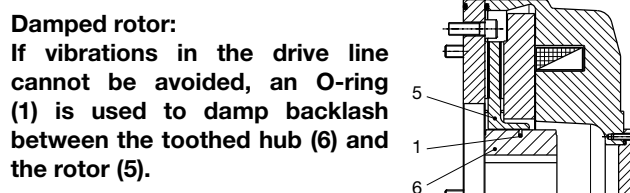

Damped rotor:
If vibrations in the drive line cannot be avoided, an O-ring (1) is used to damp backlash between the toothed hub (6) and the rotor (5).

Product Catalogue

The detailed Product Catalogue **K.891.V** _ _ _ with all constructional designs, technical data and dimensions is available for download on our website www.mayr.com.

We are also happy to send you a printed catalogue.

Perfect variety for servo pitch drives

ROBA®-servostop® safety brakes

The ROBA®-servostop® safety brakes ensure reliable, constant holding torques throughout the entire service lifetime. They feature high performance density, are wear-resistant and can also be used in challenging application conditions, such as temperatures of up to 120 °C within the motor. Furthermore, the brakes are characterised through high permitted friction work during dynamic braking: Normally, load mass ratios (load/motor) of 3:1 or smaller are selected for the benefit of good control characteristics and high dynamics. With ROBA®-servostop® brakes, load mass ratios of 30:1 and more are possible thanks to reliable friction work and friction power.

The simple and robust construction of the safety brakes allows simple, quick and reliable installation: The operating air gap is factory-specified. In contrast to permanent magnetic brakes, exact axial positioning on the motor shaft is not necessary. The ROBA®-servostop® brakes always work exactly and reliably; the magnetic air gap is not influenced by the mechanical installation situation.



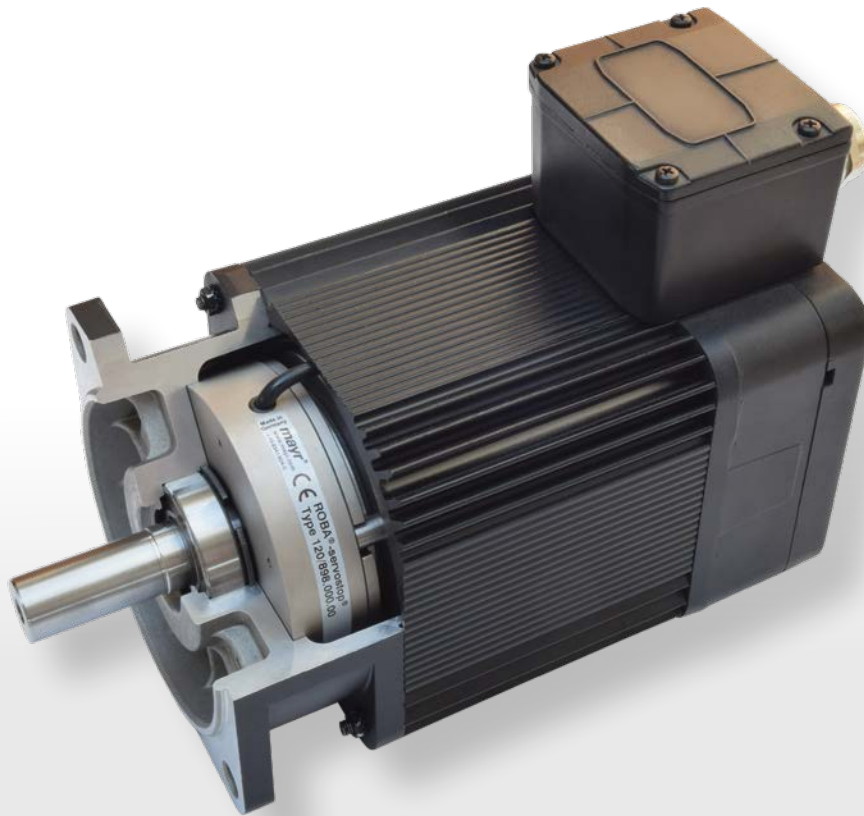

The suitable solution for every application

Servomotors are increasingly being used in the pitch sector. However, conventional brakes for servomotors cannot always cope with the high requirements placed on them by pitch applications. *mayr*® power transmission, on the other hand, offers a multitude of solutions here:

Integrated motor brakes

ROBA®-servostop®

ROBA-stop®-M

A-side flanged housing construction designs

ROBA®-topstop®

ROBA®-alphastop®

Double rotor designs with very small outer diameters based on the

ROBA-stop®-M

Product Catalogues

The detailed Product Catalogues **P.898000.V** (ROBA®-servostop®), **K.899.V** (ROBA®-topstop®), **P.897.V** (ROBA®-alphastop®) and **K.891.V** (ROBA-stop®-M) with all constructional designs, technical data and dimensions are available for download on our website www.mayr.com.

We are also happy to send you printed catalogues.

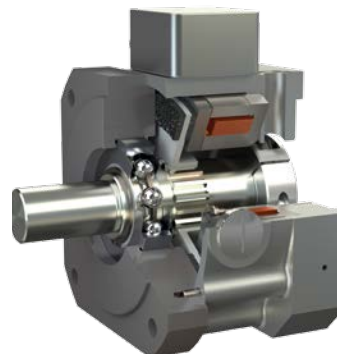

ROBA®-topstop®



ROBA®-alphastop®

Safety brakes for yaw drives

ROBA-stop®-M safety brakes

With the ROBA-stop®-M brakes, *mayr*® power transmission as the international leading manufacturer of wind power brakes not only offers safety brakes developed and tested for pitch drives, but also for yaw drives.

- Protection IP54 and IP65
- Various configuration possibilities such as hand release, release monitoring, temperature monitoring
- Combinable with ROBA®-brake-checker for sensorloses, continuous brake monitoring
- Maximised fail-safe function
- Minimum downtimes
- Improved competitive ability
- Low procurement costs
- Reduction of operating expenses
- Constructional freedom of design
- GL certification to -40 °C



Product Catalogue

The detailed Product Catalogue **K.891.V_...** with all constructional designs, technical data and dimensions is available for download on our website **www.mayr.com**.

We are also happy to send you a printed catalogue.

Permanent brake monitoring

ROBA®-brake-checker – always retaining an overview of the brake

In the wind power sector, the monitoring of electromagnetic brakes is meanwhile one of the standard requirements. Therefore, *mayr*® power transmission with its intelligent monitoring modules sets new standards for yaw and pitch brakes. The ROBA®-brake-checker module works without sensors. Instead, it detects the movement of the armature disk through the analysis of current and voltage and knows at all times in which condition the brake currently is. In addition to the switching condition, temperature and wear, it monitors the tension path or tensile force reserve, i.e. whether the magnet is still able to attract the armature disk. With the new module, substantially more processes are thus

depicted than with microswitches and sensors. On reaching the tensile force reserve, the ROBA®-brake-checker sends out a warning signal early on enough so that a certain operating time for the brake is still possible. During this time, the wind power plant operator or manufacturer can undertake maintenance in a targeted manner, aligned to their working process. In a further development stage, the module simultaneously also takes over the control of the brake and thus replaces the rectifier. In this way, the switching condition monitoring and the brake control are combined in one device.

Under continuous supervision – without additional sensors

The ROBA®-brake-checker is the perfect activation and control module for pitch and yaw brakes. All the important functions for the monitoring and supply of safety brakes are integrated.

- Release monitoring
- Wear monitoring
- Monitoring of critical coil temperatures
- Integrated overexcitation and drop in voltage

For pitch brakes, the following are preferred modules

ROBA®-brake-checker DC and
ROBA®-brake-checker plus DC are used.



For yaw brakes, the following modules are the most suitable

ROBA®-brake-checker AC and
ROBA®-brake-checker plus AC



We raise you safely to your destination

Brakes and clutches for tower elevators and climbing aids

The elevator is considered the safest means of transportation in the world. The EN 81 standard and the ASME code specify redundant brake systems in terms of as high a level of personal safety as possible. In accordance with the current status, however, tower elevators and service elevators in wind power plants are still excluded from these standards. These are subject to the Machinery Directive. *mayr*[®] power transmission – the world market leader for elevator brakes – provides, in addition to the single circuit brakes still permitted today for winches, a wide range of redundant safety brakes. This technology will also facilitate the fulfilment of international standards worldwide in future.

And if the wind power plant has no elevator at all, then the service technician must ascend the tower in an arduous and strenuous process in full gear via a ladder. Supporting climbing aids facilitate the ascent. These pull permanently upwards with a defined force. If the service technician has to stop briefly or if they are unable to keep up with the speed of the ascent, the drive does not switch off the climbing aid immediately. In such cases, an integrated torque limitation, for example a frictionally-locking *ROBA*[®]-slip hub or a positive locking *EAS*[®]-Compact[®] torque limiter, bridges the fault.

Safety brakes for tower elevators and service lifts

ROBA-stop[®]-M

Reliable single circuit brake for winches

ROBA-stop[®]-silenzio

Tried and tested redundant dual circuit brake – certified in accordance with EN 81 for all passenger elevators

Torque limiters for climbing aids

ROBA[®]-slip hub

The load-holding, frictionally-locking torque limiter

EAS[®]-Compact[®]

The load-separating, positive locking torque limiter



ROBA-stop[®]-M



ROBA-stop[®]-silenzio



ROBA[®]-slip hub



EAS[®]-Compact[®]



Safe and efficient work sky-high

Installation and maintenance platforms greatly facilitate work on wind power plants and are becoming increasingly sophisticated in technical terms. With their assistance, it is possible to build new wind farms quickly, efficiently and safely. Here, too, ROBA-stop® brakes ensure the safety of assembly and service technicians. The electromagnetic “energise to engage” clutches and brakes ROBATIC® and ROBA®-quick are used in auxiliary drive fields of application.



ROBA-stop®-M



ROBA®-quick



ROBATIC®

ROBA-stop®

Spring applied torque limiters
in accordance with the fail-safe principle

ROBATIC®

Energised-to-engage electromagnetic clutches

ROBA®-quick

Energised-to-engage electromagnetic brakes



Brakes and couplings in an offshore hardness test

Installation and maintenance ships must stand safely before it is possible to start work on wind power plants. To do this, mainstays with so-called jack-ups are driven into the sea floor. Once the correct position has been achieved, special brakes ensure a secure hold. ROBA-stop[®]-S safety brakes are the best choice here. With Protection IP67 and special corrosion protection, they are able to cope with the adverse conditions on the sea.

In addition to safety brakes, special clutches are also used here with appropriate certifications such as ABS or DNV GL.

ROBA-stop[®]-S

Sealed and corrosion-resistant safety brake in Protection IP67

ROBA[®]-DS

Robust, backlash-free all-steel disk pack coupling with DNV GL certification



ROBA-stop[®]-S



ROBA[®]-DS



Overload protection for the main drive

Wind power plants are not safe against overloads in the main drive which are introduced from the generator side or which are caused through the uncontrollable behaviour of the wind. In order to protect against expensive component damages, load-holding overload systems are integrated between the generator and gears on conventional gear drives and on so-called semidrive systems. These absorb unpermittedly high torque peaks.

ROBA®-slip hub

Frictionally-locking torque limiter
with a torque of over 100,000 Nm

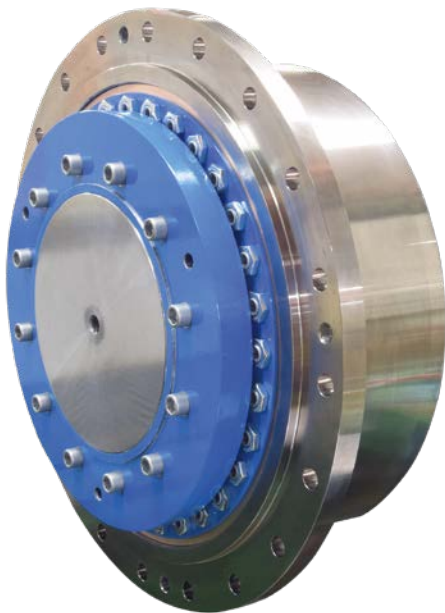



Reliable small wind turbines acc. IEC DIN EN 61400-2

The electromagnetic caliper brakes ROBA®-diskstop® are suitable for the main drive of small wind power plants with and without a pitch system. Through the assembly of several callipers on a disk or through enlargement of the disk diameter, very high braking torques can be realised.

As very high levels of friction work may occur, above all on systems without a pitch system due to the permanent wind load, conventional friction linings frequently prove insufficient. *mayr*® power transmission has produced special sinter linings specifically for the purpose in its own Research and Development Department.

Reliable brake dimensioning is essential here. Please request our questionnaire on brakes for small wind power plants.

ROBA®-diskstop®

Safety brake systems for brake disks

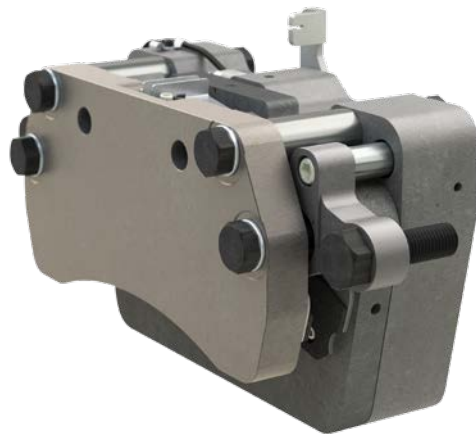

Application in test stand technology

High-precision couplings for accurate measuring results

Whether for gears or bearing test stands, for torque measurements or load tests on rotor blades – mayr® power transmission develops solutions for test stand technology which grow with the increasingly complex concepts.

High-speed torque limiters

The high-speed torque limiters, which protect expensive test objects and sensitive measuring units against overload damage, have been especially tailored to the requirements of test stand technology and work reliably and accurately also at very high speeds. If the torque exceeds the limit value set on the torque limiter, the clutch disengages and separates the input and output within seconds. After a case of

overload, the measuring shaft therefore has to be recalibrated at most; the torque limiter reliably prevents any further expensive damage to the drive line or test object.

High-precision shaft couplings

One essential accessory part – not only for measurement flanges – is the high-precision shaft coupling, which compensates for any occurring misalignments. It protects the bearings installed in the shaft train against unwanted loads, and therefore against unnecessary downtimes and costs, and ensures reliable and accurate measurement results.



**ROBA®-DS shaft coupling
for high torques**



**ROBA®-DS shaft coupling
for torque transducer**

For the combination of shaft coupling and torque limiter, mayr® power transmission offers complete solutions from a single source.

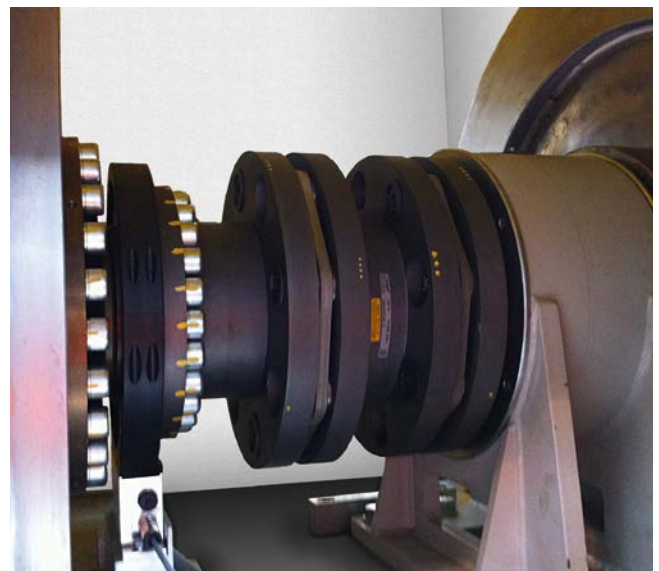

EAS®-HT torque limiter

Specialist for power transmission

Tried and tested solutions for production and manufacturing lines

In the field of handling and automation, *mayr*[®] power transmission has developed high-performance safety brakes which are perfectly tailored to the high demands. Here the spectrum ranges from robust lightweight construction brakes via modular brake systems for attachment to servomotors, right up to profiled rail brakes and linear brakes. The safety brakes permanently guarantee the reliable protection of people and material, and prove their worth daily in countless robot and handling applications worldwide.

Your reliable partner

Besides brakes, the clutches/couplings by *mayr*[®] power transmission also render reliable services in robotics and automated solutions. A wide spectrum of backlash-free, high-performance servo couplings ensures a reliable connection between the shafts. These proven torque limiters stand for permanently reliable overload protection – for maximum operating safety and productivity.

At a glance

mayr[®] products in operation in wind power technology

<i>mayr</i> [®]	Electromagn. brakes	Overload clutches	Shaft couplings	Electromagn. clutches
Pitch drive	X		X	
Yaw drive	x	x		
Main drive		x	x	
Service elevators	x			
Hoisting devices	x	x		
Climbing aids		x		
Installation platforms	x	x		x
Test stands	x	x	x	x
Assembly lines	x	x	x	x
Small wind turbines	x	x	x	

Headquarters

Chr. Mayr GmbH + Co. KG
Eichenstraße 1, D-87665 Mauerstetten
Tel.: +49 83 41/8 04-0, Fax: +49 83 41/80 44 21
www.mayr.com, E-Mail: info@mayr.com

mayr[®]
your reliable partner

Service Germany/Austria

Baden-Württemberg

Esslinger Straße 7
70771 Leinfelden-Echterdingen
Tel.: 07 11/45 96 01 0
Fax: 07 11/45 96 01 10

Bavaria

Industriestraße 51
82194 Gröbenzell
Tel.: 0 81 42/50 19 80-7

Chemnitz

Bornaer Straße 205
09114 Chemnitz
Tel.: 03 71/4 74 18 96
Fax: 03 71/4 74 18 95

Franken

Unterer Markt 9
91217 Hersbruck
Tel.: 0 91 51/81 48 64
Fax: 0 91 51/81 62 45

Kamen

Herbert-Wehner-Straße 2
59174 Kamen
Tel.: 0 23 07/24 26 79
Fax: 0 23 07/24 26 74

North

Schiefer Brink 8
32699 Extertal
Tel.: 0 57 54/9 20 77
Fax: 0 57 54/9 20 78

Rhine-Main

Kreuzgrundweg 3a
36100 Petersberg
Tel.: 06 61/96 21 02 15

Austria

Pummerinplatz 1, TIZ I, A27
4490 St. Florian, Austria
Tel.: 0 72 24/2 20 81-12
Fax: 0 72 24/2 20 81 89

Branch Offices

China

Mayr Zhangjiagang
Power Transmission Co., Ltd.
Fuxin Road No.7, Yangshe Town
215637 Zhangjiagang
Tel.: 05 12/58 91-75 67
Fax: 05 12/58 91-75 66
info@mayr-ptc.cn

Great Britain

Mayr Transmissions Ltd.
Valley Road, Business Park
Keighley, BD21 4LZ
West Yorkshire
Tel.: 0 15 35/66 39 00
Fax: 0 15 35/66 32 61
sales@mayr.co.uk

France

Mayr France S.A.S.
Z.A.L. du Minopole
Rue Nungesser et Coli
62160 Bully-Les-Mines
Tel.: 03.21.72.91.91
Fax: 03.21.29.71.77
contact@mayr.fr

Italy

Mayr Italia S.r.l.
Viale Veneto, 3
35020 Saonara (PD)
Tel.: 0498/79 10 20
Fax: 0498/79 10 22
info@mayr-italia.it

Singapore

Mayr Transmission (S) PTE Ltd.
No. 8 Boon Lay Way Unit 03-06,
TradeHub 21
Singapore 609964
Tel.: 00 65/65 60 12 30
Fax: 00 65/65 60 10 00
info@mayr.com.sg

Switzerland

Mayr Kupplungen AG
Tobelackerstraße 11
8212 Neuhausen am Rheinfall
Tel.: 0 52/6 74 08 70
Fax: 0 52/6 74 08 75
info@mayr.ch

USA

Mayr Corporation
10 Industrial Avenue
Mahwah
NJ 07430
Tel.: 2 01/4 45-72 10
Fax: 2 01/4 45-80 19
info@mayrcorp.com

Turkey

Representative Office Turkey
Kucukbakkalkoy Mah.
Brandium Residence R2
Blok D:254
34750 Atasehir - Istanbul, Turkey
Tel.: 02 16/2 32 20 44
Fax: 02 16/5 04 41 72
info@mayr.com.tr

Representatives

Australia

Drive Systems Pty Ltd.
12 Sommersby Court
Lysterfield, Victoria 3156
Australia
Tel.: 0 3/97 59 71 00
dean.hansen@drivesystems.com.au

India

National Engineering
Company (NENCO)
J-225, M.I.D.C.
Bhosari Pune 411026
Tel.: 0 20/27 13 00 29
Fax: 0 20/27 13 02 29
nenco@nenco.org

Japan

MATSUI Corporation
2-4-7 Azabudai
Minato-ku
Tokyo 106-8641
Tel.: 03/35 86-41 41
Fax: 03/32 24 24 10
k.goto@matsui-corp.co.jp

Netherlands

Groneman BV
Amarilstraat 11
7554 TV Hengelo OV
Tel.: 074/2 55 11 40
Fax: 074/2 55 11 09
aandrijftechniek@groneman.nl

Poland

Wamex Sp. z o.o.
ul. Pozaryskiego, 28
04-703 Warszawa
Tel.: 0 22/6 15 90 80
Fax: 0 22/8 15 61 80
wamex@wamex.com.pl

South Korea

Mayr Korea Co. Ltd.
15, Yeondeok-ro 9beon-gil
Seongsan-gu
51571 Changwon-si
Gyeongsangnam-do, Korea
Tel.: 0 55/2 62-40 24
Fax: 0 55/2 62-40 25
info@mayrkorea.com

Taiwan

German Tech Auto Co., Ltd.
No. 28, Fenggong Zhong Road,
Shengang Dist.,
Taichung City 429, Taiwan R.O.C.
Tel.: 04/25 15 05 66
Fax: 04/25 15 24 13
abby@zfgta.com.tw

Czech Republic

BMC - TECH s.r.o.
Hviezdoslavova 29 b
62700 Brno
Tel.: 05/45 22 60 47
Fax: 05/45 22 60 48
info@bmc-tech.cz

More Representatives:

Belgium, Brazil, Denmark, Finland, Greece, Hong Kong, Indonesia, Israel, Canada, Columbia, Croatia, Luxembourg, Malaysia, Mexico, New Zealand, Norway, the Philippines, Portugal, Romania, Russia, Sweden, Slovakia, Slovenia, South Africa, Spain, Thailand, Hungary

You can find the complete address for the representative responsible for your area under www.mayr.com on the Internet.