



HANPU TOOLS

Specially used in petrochemical, wind power, large-scale engineering machinery and other industries

ELECTRIC TORQUE WRENCH



CHARACTERISTICS

Adopt digital display controller, easy to control and high repeatability.

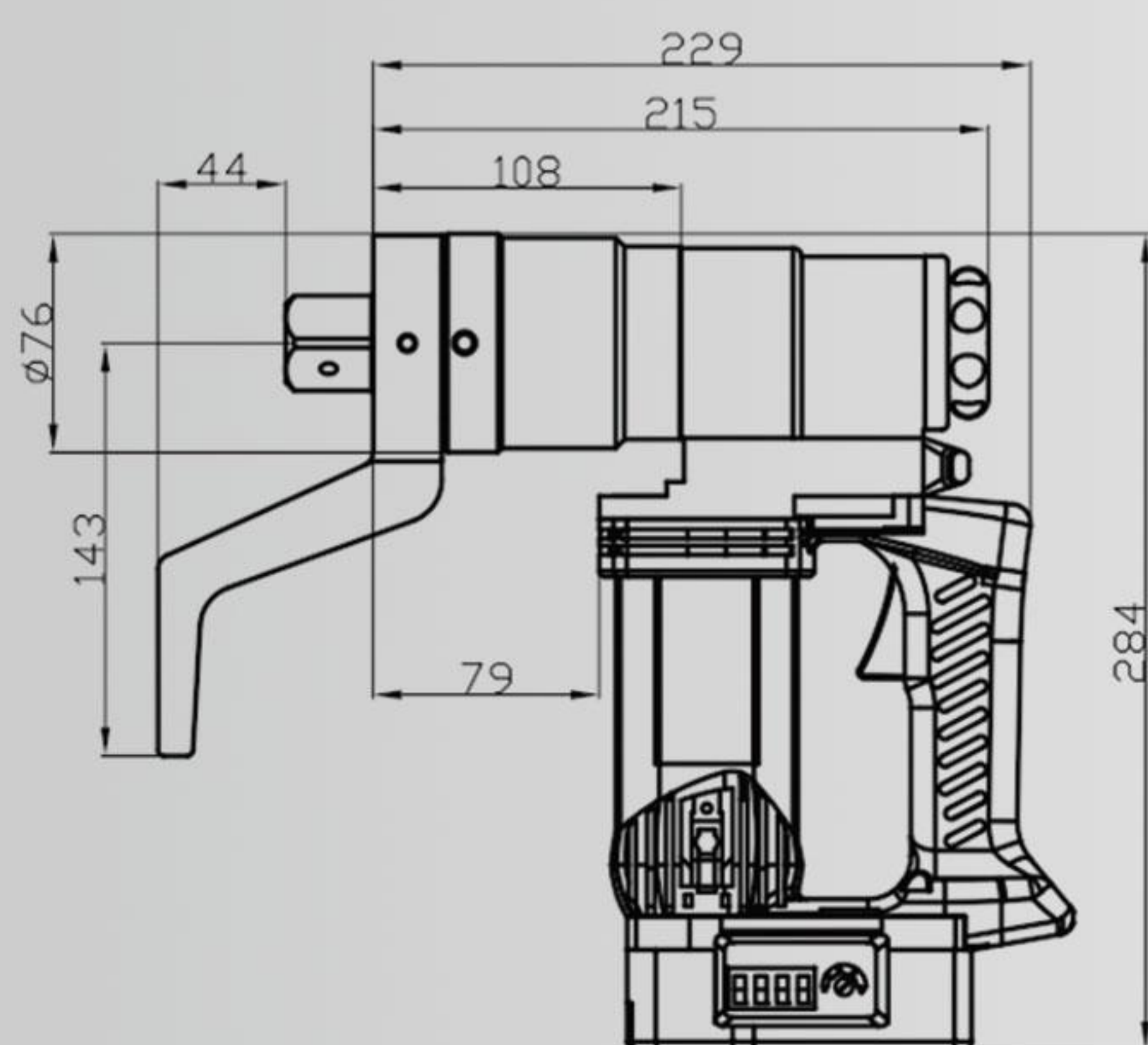

Electric Torque Wrench **TL-12LP**

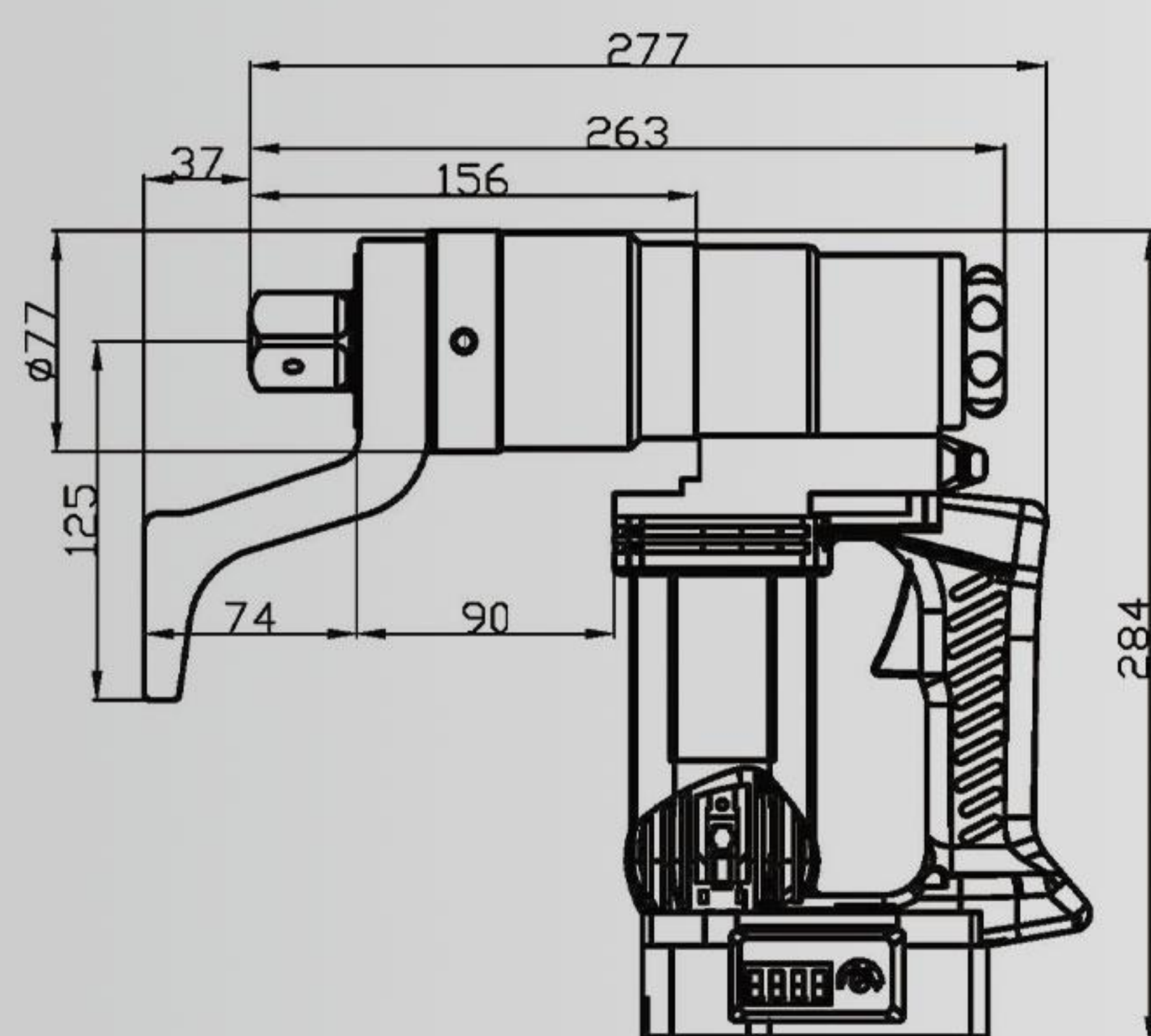

Electric Torque Wrench **TL-15LP**

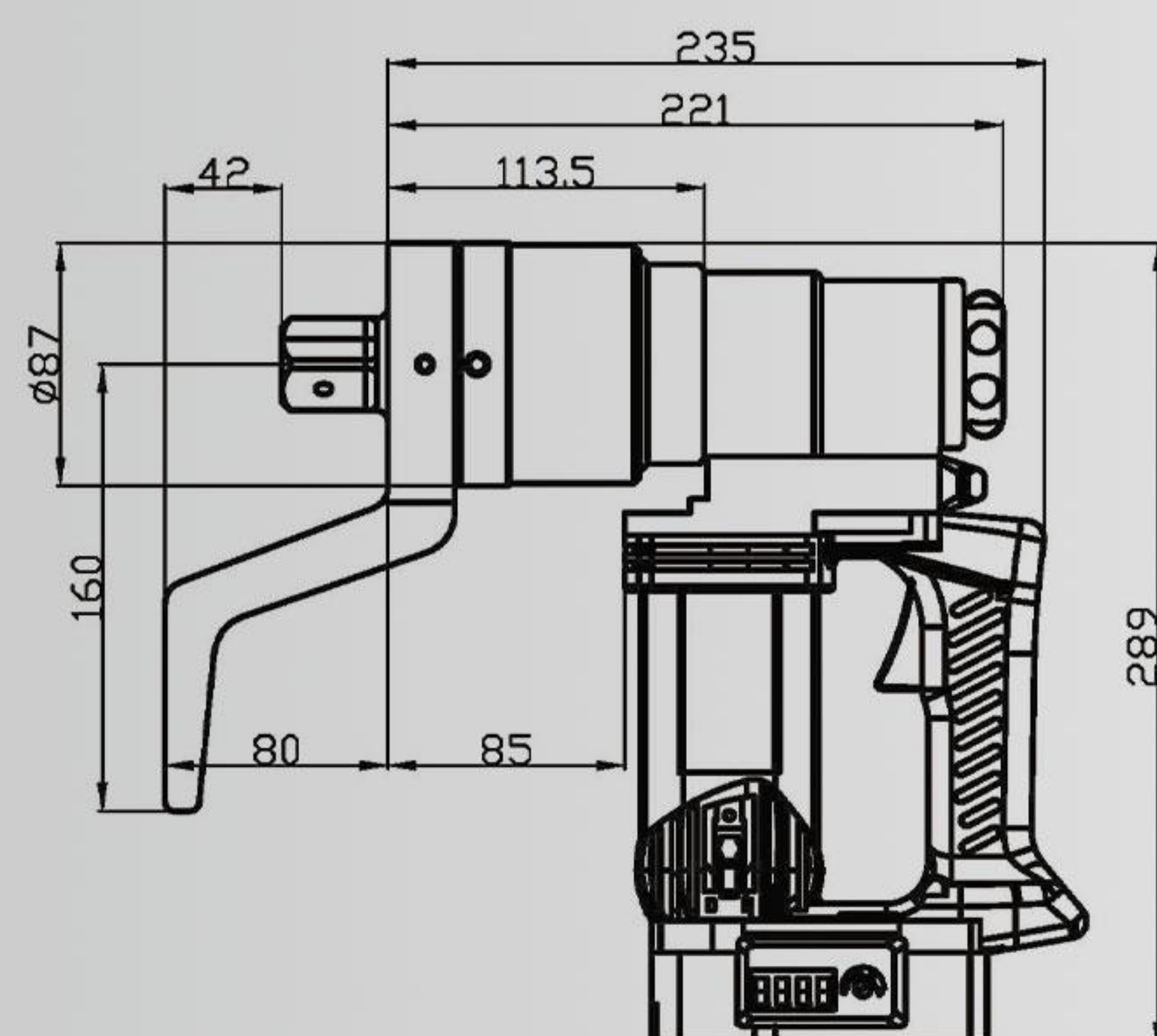

Electric Torque Wrench **TL-21LP**

MODEL	FREQ	VOLTAGE	MAX CURRENT	MAX POWER CONSUMPTION	TORQUE RANGE	RO SPEED (min-1)	WEIGHT	SQUARE DRIVE	PROTECT CLASS	DAPTABLE BOLTS DIA		
										S-10T	A325	A490
TL-12LP	50-60Hz	230V 115V	8A/16A	1800W	500-1200N.m	9rpm	5.5KG	25.4x25.4mm (1"x1")	Double Insulation	M22 M24	7/8" 1"	7/8" 1"
TL-15LP	50-60Hz	230V 115V	8A/16A	1800W	500-1500N.m	7.5rpm	5.5KG	25.4x25.4mm (1"x1")	Double Insulation	M22 M24 M27	7/8" 1" 1-1/8"	7/8" 1"
TL-21LP	50-60Hz	230V 115V	8A/16A	1800W	900-2100N.m	6rpm	6.6KG	25.4x25.4mm (1"x1")	Double Insulation	M27 M30	1-1/8" 1-1/4"	1-1/8" 1-1/4"

Adopts standard square head, wrench without socket.

ELECTRIC TORQUE WRENCH

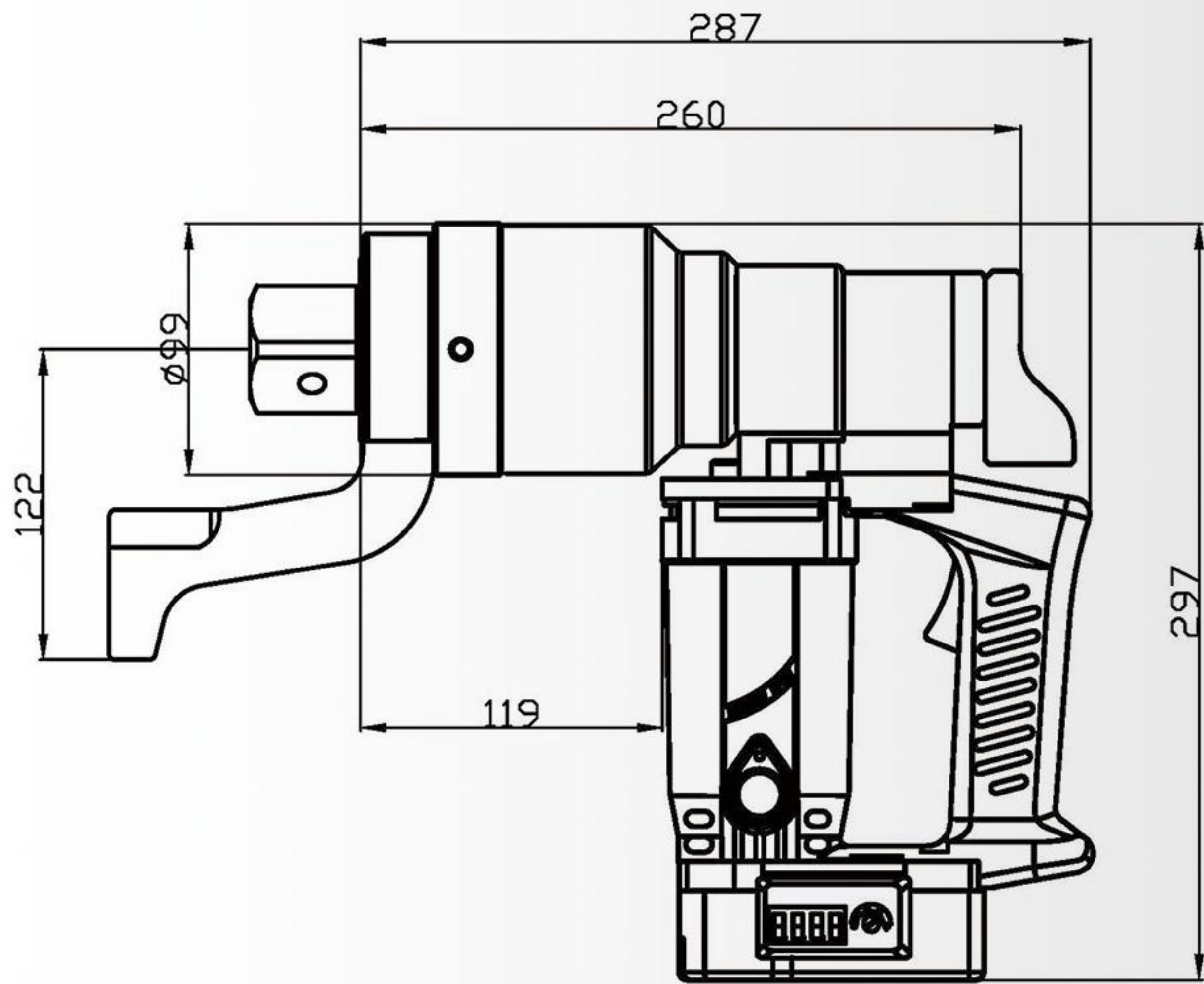

Electric Torque Wrench **TL-35G**

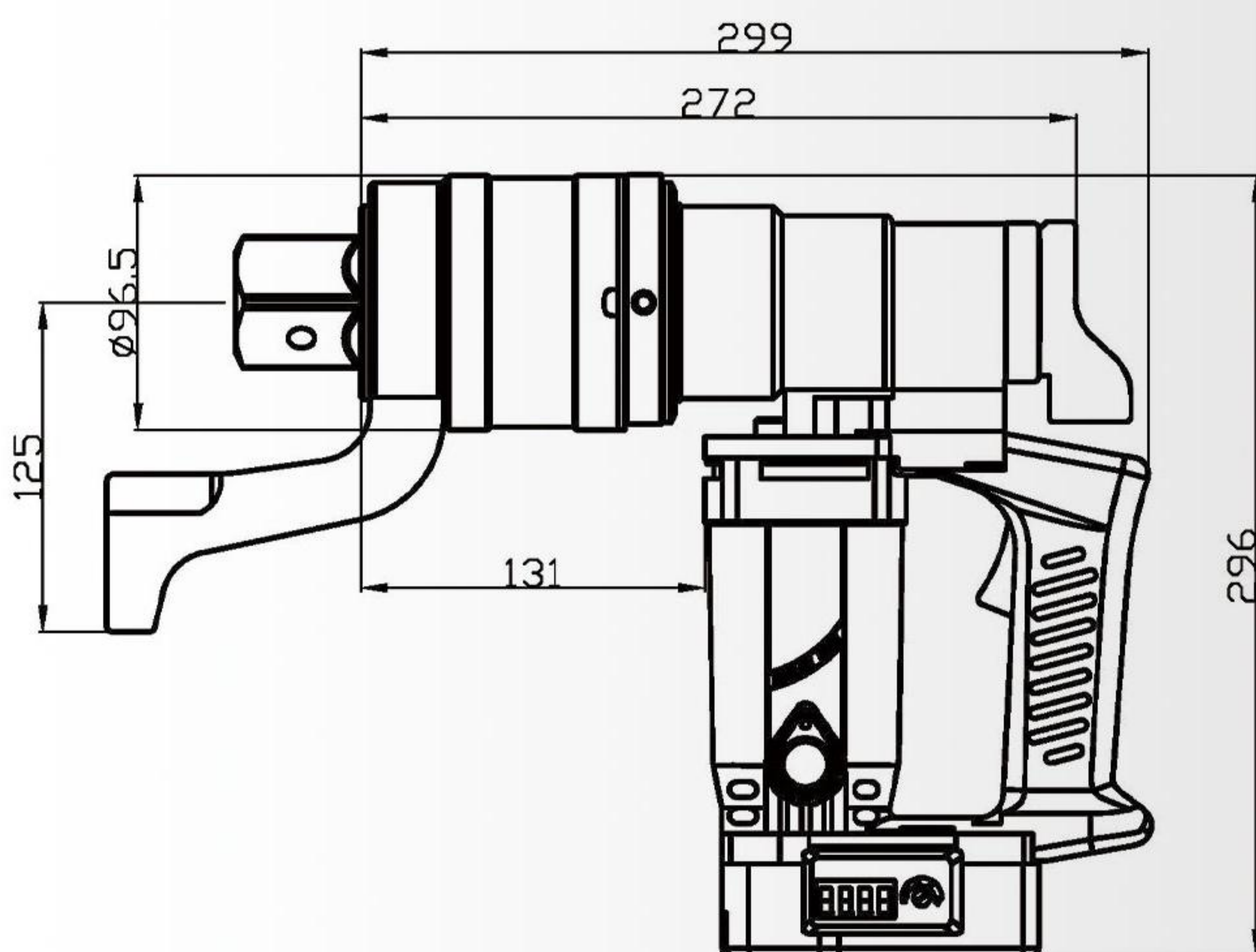

Electric Torque Wrench **TL-50G**

MODEL	FREQ	VOLTAGE	MAX CURRENT	MAX POWER CONSUMPTION	TORQUE RANGE	RO SPEED (min-1)	WEIGHT	SQUARE DRIVE	PROTECT CLASS	DAPTABLE BOLTS DIA		
										S-10T	A325	A490
TL-35G	50-60Hz	230V 115V	12A/24A	2800W	1500-3500N.m	2.5rpm	11KG	38x38mm (1-1/2"x1-1/2")	Double Insulation	M30 M33 M36	1-1/4" 1-3/8" 1-1/2"	1-1/4" 1-3/8"
TL-50G	50-60Hz	230V 115V	12A/24A	2800W	1000-5000N.m	4rpm	10.6KG	38x38mm (1-1/2"x1-1/2")	Double Insulation	M27 M30 M33 M36 M42 M45	1-1/8" 1-1/4" 1-3/8" 1-1/2" 1-5/8" 1-3/4"	1-1/8" 1-1/4" 1-3/8" 1-1/2" 1-5/8"

Adopts standard square head, wrench without socket.

ELECTRIC TORQUE WRENCH

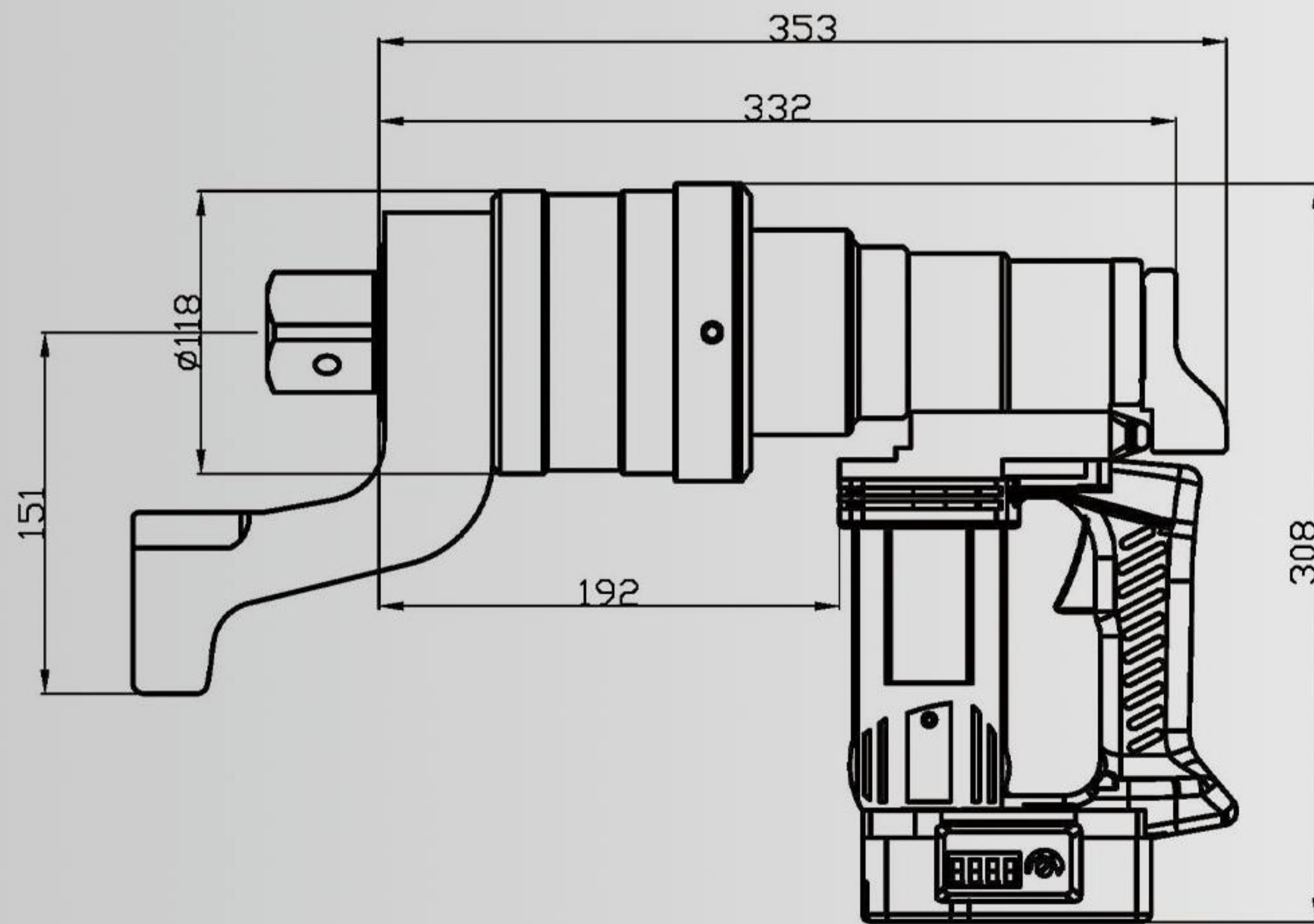

Electric Torque Wrench **TL-100G**

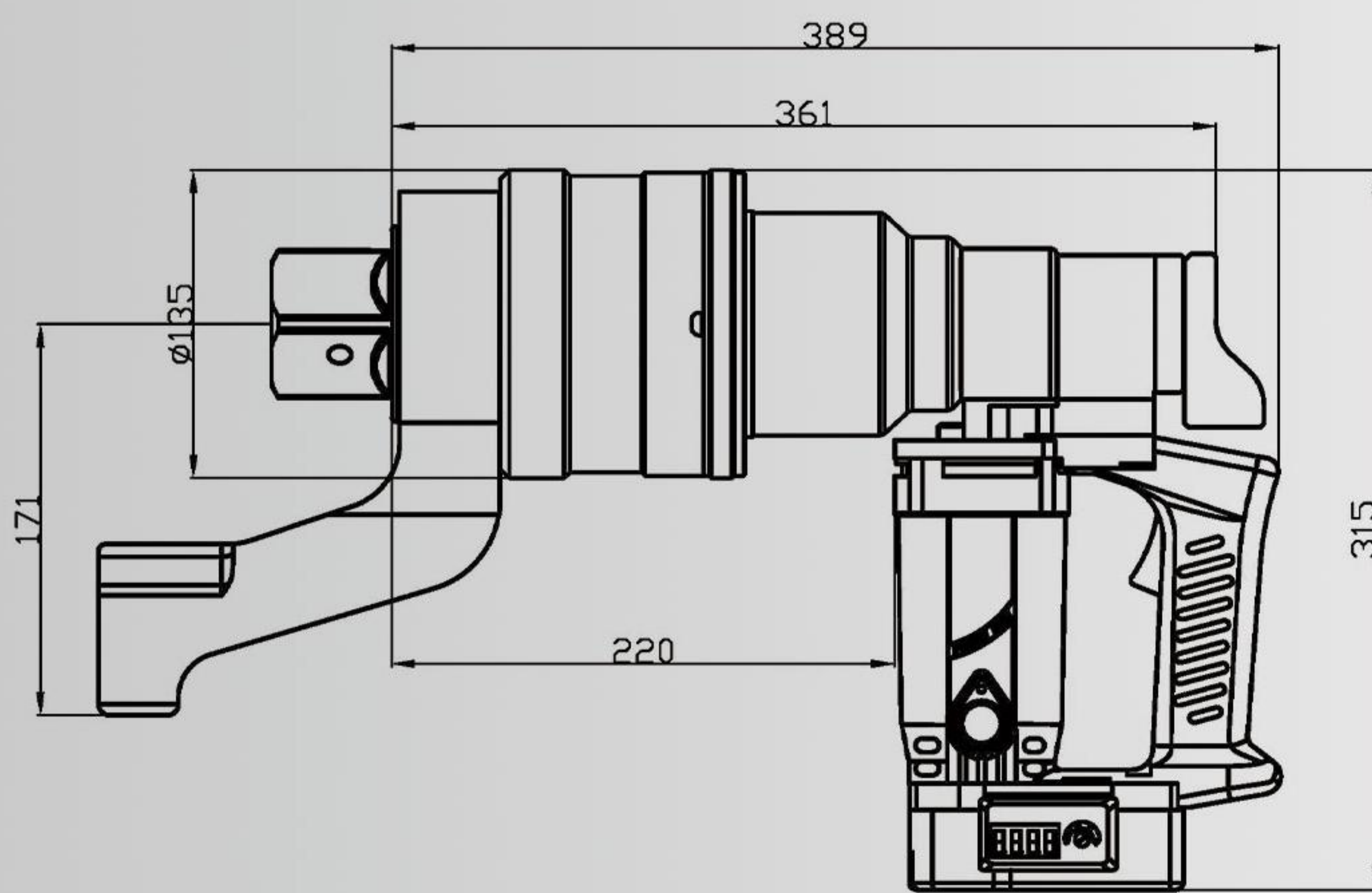

Electric Torque Wrench **TL-150G**

MODEL	FREQ	VOLTAGE	MAX CURRENT	MAX POWER CONSUMPTION	TORQUE RANGE	RO SPEED (min-1)	WEIGHT	SQUARE DRIVE	PROTECT CLASS	DAPTABLE BOLTS DIA		
										S-10T	A325	A490
TL-100G	50-60Hz	230V 115V	8A/16A	1800W	3000-10000N.m	1.5rpm	14KG	38x38mm (1-1/2"x1-1/2")	Double Insulation	M36 M42 M45 M48 M52 M56	1-1/2" 1-5/8" 1-3/4" 2" 2-1/8" 2-1/4"	1-1/2" 1-5/8" 1-3/4" 2" 2-1/8"
TL-150G	50-60Hz	230V 115V	12A/24A	2800W	5000-15000N.m	1rpm	16.5KG	50x50mm (2"x2")	Double Insulation	M45 M48 M52 M56 M60	1-3/4" 2" 2-1/8" 2-1/4" 2-1/2"	1-3/4" 2" 2-1/8" 2-1/8" 2-1/4"

Adopts standard square head, wrench without socket.

PORTABLE BOLT TORQUE TESTER



CHARACTERISTICS

1. Suitable for torque value detection after final tightening of large hexagonal high-strength bolts. Light and labor-saving, suitable for operation in narrow spaces, High rate torque amplification, and requires only one person and one hand during operation.
2. Equipped with a high-precision sensor at the torque output end to make the detection data more accurate and reliable

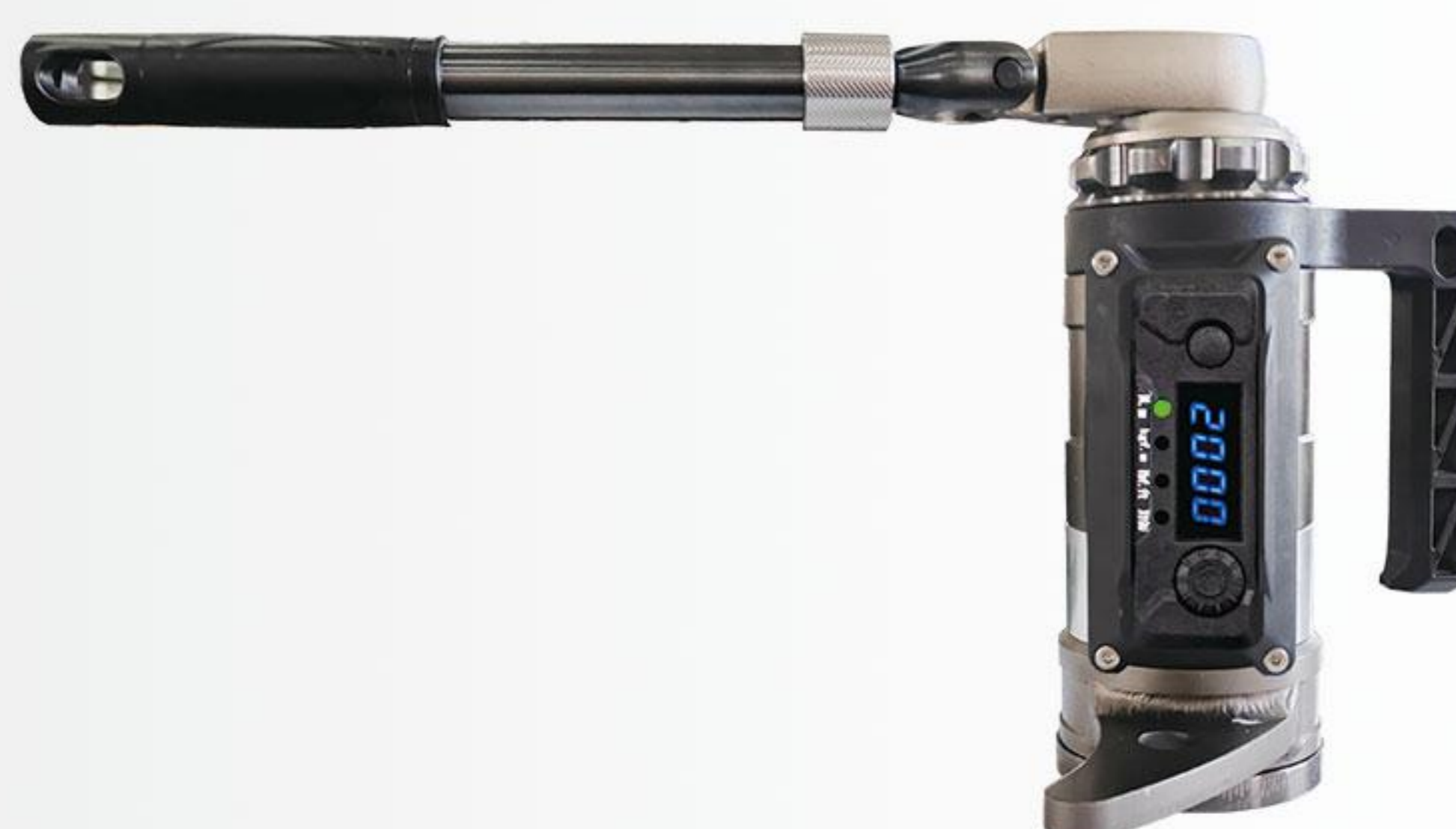
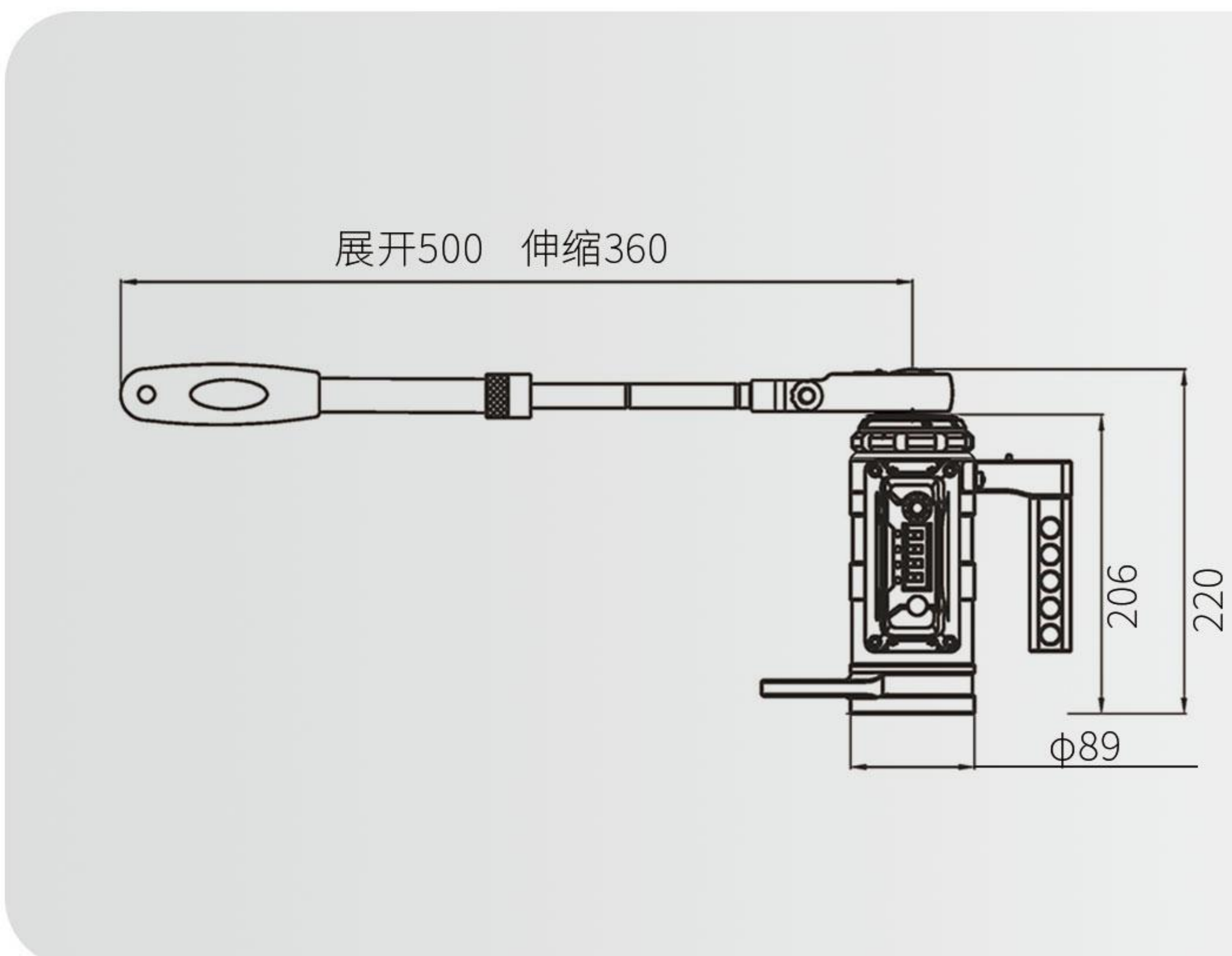

Portable Bolt Torque Tester **SF-2000**

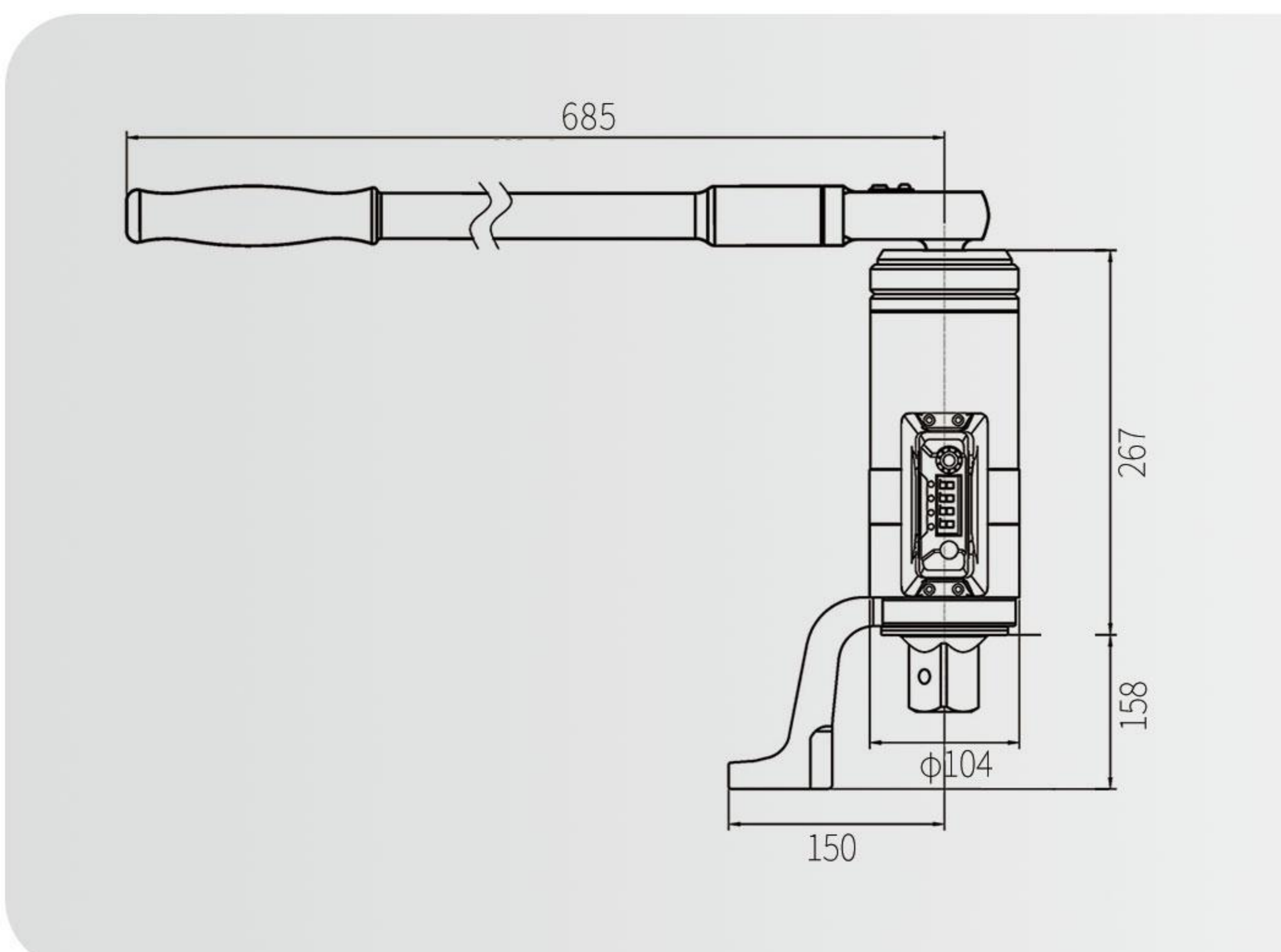

Portable Bolt Torque Tester **SF-5000**

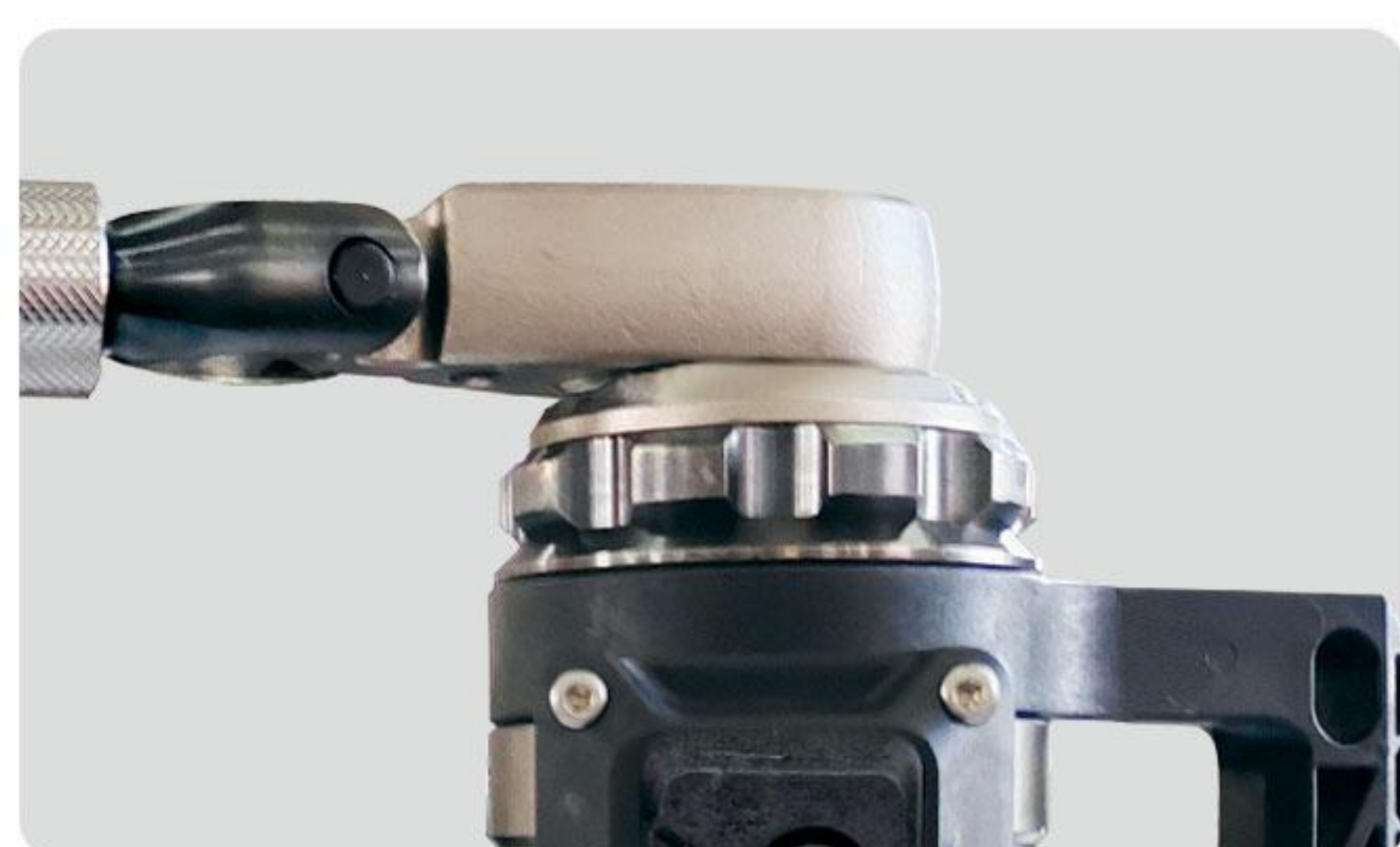

Black ratchet



High precision sensor & Digital display



Rotatable handle

Model	Max Torque	Torque Range	CA	Gear Ratio	Weight	Square Drive	Adaptable Bolts Dia
SF-2000	2000N.m	50-2000N.m	±1%	1:18	6KG	12.7x12.7mm 1/2"x1/2"	M20 M22 M24 M27 M30
SF-5000	5000N.m	50-5000N.m	±3%	1:15	16KG	19x19mm 3/4"x3/4"	M22 M24 M27 M30 M33 M36 M42

ABOUT HANPU ■■

Shandong Hanpu Machinery Industry Co.,Ltd.is located in Qihe Economic Development Zone, Dezhou City,Shandong Province.It s a high-tech enterprise,integrating:production,research and development,and sales.With over 20 years development,now we have 62 acres factory ,which includes a production and R&D workshop of 30,000 m². .Hanpu has imported a large number of processing equipment that made in Switzerland,Germany,and Japan,and successfully developed and produced a variety of professional fastening tools, occupying an important position in the international market.

As a leading international electric fastening tools manufacturer, Hanpu mainly produces electric shear wrench, electric torque wrench, manual shear wrench,manual torque wrench,portable bolt torque tester,electric tension and torque calibrator,etc.The product is widely used in power plant construction,bridge construction,metallurgical construction,high-rise buildings,mechanical equipment installation,wind power construction,nuclear power construction,oil pipelines,railway construction,automobile asembly and other steel structure installation industries.

Over the years,based on the principle of quality first,Hanpu fully understand the actual needs of customers.At present,it has served many large-scale projects,and the product has been sold well in North America,South America,the Middle East,European markets and so many countries and regions.



Shandong Hanpu Machinery Industry Co.,Ltd.

Factory Add: Qihe high-tech Development Zone, Dezhou, Shandong

Office Add: Room 1812, Building A, Wanda Plaza, No.9 Jingsi Road, Jinan, Shandong

Ph.: +86 18653495537 0531-83530061-1806

Fax: 0531-83530747

Web: www.hanpuindustrial.com

www.hptorquewrench.com

E-mail: info@hanputool.com

Tech@hanputool.com



Official Website